



Untyred wheels can carry high loads with low rolling resistance when used on a hard surface such as flat steel. On softer surfaces, such as concrete or tarmac, the surface is likely to be worn or indented by the use of an untyred wheel. Untyred wheels are noisier in operation than tyred wheels, but noise is unlikely to be a problem at walking speeds.

**MATERIAL:** Cast iron to BS1452: 1977: Grade 200.

**OPERATING TEMPERATURE RANGE:**

- Plain bored or keywayed wheels – 30°C to 250°C
- Ball or taper roller bearinged wheels – 30°C to 120°C

Alternative bore/bearing diameters and alternative bearing types (i.e. bronze bushes, self-lubricating bushes, roller bearings, spherical roller bearings, etc.) are available to order – see page 26-27.

For wheels of larger diameter or greater load capacity see the CFT series (pages 48 & 49) and SFT series (pages 45-47).

For technical information covering load factors, inertial and rolling resistance, coefficients of friction between wheel and track, and keyway dimensions, see “Design Data” Index on page 20.

Drawings show grease nipple but standard wheels do not come with grease nipple unless specifically requested.

**WHEEL TYPE:**  
**C75/40**  
See table for full part number

**Maximum load rating:**  
**400Kg**  
See page 23-26 for load factors  
**Approximate weight: 0.75Kg**

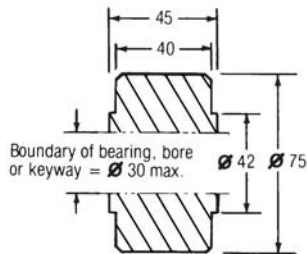

Wheels fitted with ball journals are pre-lubricated, double shielded

**WHEEL TYPE:**  
**C100/30**  
See table for full part number

**Maximum load rating:**  
**400Kg**  
See page 23-26 for load factors  
**Approximate weight: 1Kg**

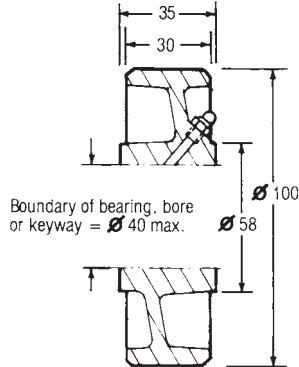

FULL PART NUMBER FOR ORDERING				
Axle Ø	Plain Bore	Plain Bore Keywayed	Ball Bearing	Taper Roller Bearing
<b>METRIC AXLE Ø</b>				
12	C75/40/PBM 12	C75/40/KM 12	C75/40/BJM 12	
20	C75/40/PBM 20	C75/40/KM 20		
25	C75/40/PBM 25	C75/40/KM 25		

<b>METRIC AXLE Ø</b>				
20	C100/30/PBM 20	C100/30/KM 20	C100/30/BJM 20	
25	C100/30/PBM 25	C100/30/KM 25		
30	C100/30/PBM 30	C100/30/KM 30		

# Cast Iron Untyred Wheels



## WHEEL TYPE: C100/45

See table for full part number

Maximum load rating:  
**600Kg**

See page 23-26 for load factors

Approximate weight: **1.5Kg**

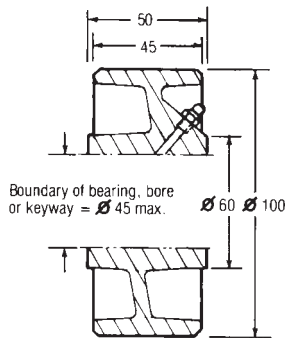

### FULL PART NUMBER FOR ORDERING

Axle Ø	Plain Bore	Plain Bore Keywayed	Ball Bearing	Taper Roller Bearing
<b>METRIC AXLE Ø</b>				
25	C100/45/PBM 25	C100/45/KM 25	C100/45/BJM 25	
30	C100/45/PBM 30	C100/45/KM 30		

## WHEEL TYPE: C125/35

See table for full part number

Maximum load rating:  
**550Kg**

See page 23-26 for load factors

Approximate weight: **1.5Kg**

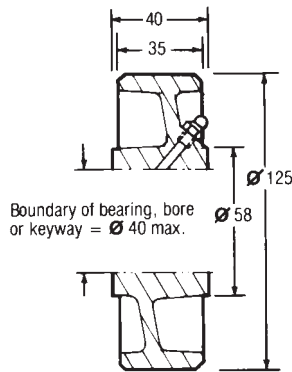

<b>METRIC AXLE Ø</b>				
20	C125/35/PBM 20	C125/35/KM 20	C125/35/BJM 20	
25	C125/35/PBM 25	C125/35/KM 25		
30	C125/35/PBM 30	C125/35/KM 30		

## WHEEL TYPE: C125/50

See table for full part number

Maximum load rating:  
**800Kg**

See page 23-26 for load factors

Approximate weight: **2.5Kg**

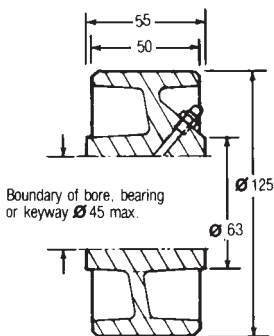

<b>METRIC AXLE Ø</b>				
25	C125/50/PBM 25	C125/50/KM 25	C125/50/BJM 25	
30	C125/50/PBM 30	C125/50/KM 30		

## WHEEL TYPE: C150/40

See table for full part number

Maximum load rating:  
**800Kg**

See page 23-26 for load factors

Approximate weight: **2.5Kg**

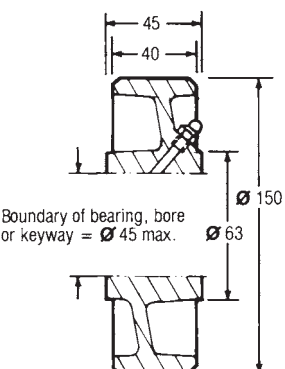

<b>METRIC AXLE Ø</b>				
25	C150/40/PBM 25	C150/40/KM 25	C150/40/BJM 25	
30	C150/40/PBM 30	C150/40/KM 30		

CAST IRON UNTYRED

**WHEEL TYPE:**

## C150/60

See table for full part number

**Maximum load rating:**

**1200Kg**

See page 23-26 for load factors

**Approximate weight: 3.5Kg**

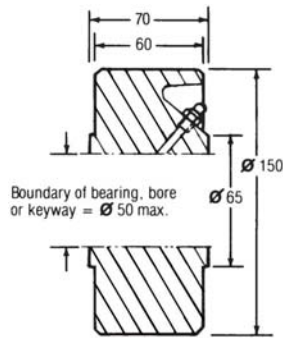

### FULL PART NUMBER FOR ORDERING

Axle Ø	Plain Bore	Plain Bore Keywayed	Ball Bearing	Taper Roller Bearing
<b>METRIC AXLE Ø</b>				
25	C150/60/PBM 25	C150/60/KM 25	C150/60/BJM 25	
30	C150/60/PBM 30	C150/60/KM 30		
35	C150/60/PBM 35	C150/60/KM 35		

LOAD LIMITED BY BEARINGS TO: (1) 1140Kg

**WHEEL TYPE:**

## C200/45

See table for full part number

**Maximum load rating:**

**1200Kg**

See page 23-26 for load factors

**Approximate weight: 4.5Kg**

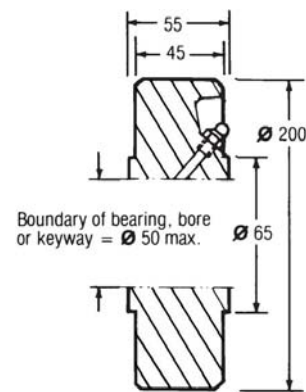

Axle Ø	Plain Bore	Plain Bore Keywayed	Ball Bearing	Taper Roller Bearing
<b>METRIC AXLE Ø</b>				
25	C200/45/PBM 25	C200/45/KM 25	C200/45/BJM 25	
30	C200/45/PBM 30	C200/45/KM 30		
35	C200/45/PBM 35	C200/45/KM 35		

LOAD LIMITED BY BEARINGS TO: (1) 1140Kg

**WHEEL TYPE:**

## C200/70

See table for full part number

**Maximum load rating:**

**1800Kg**

See page 23-26 for load factors

**Approximate weight: 8Kg**

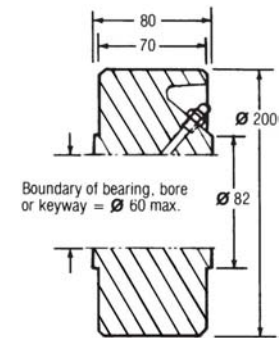

Axle Ø	Plain Bore	Plain Bore Keywayed	Ball Bearing	Taper Roller Bearing
<b>METRIC AXLE Ø</b>				
30	C200/70/PBM 30	C200/70/KM 30	C200/70/BJM 30	
35	C200/70/PBM 35	C200/70/KM 35		
40	C200/70/PBM 40	C200/70/KM 40		
50	C200/70/PBM 50	C200/70/KM 50		

**WHEEL TYPE:**

## C250/50

See table for full part number

**Maximum load rating:**

**1600Kg**

See page 23-26 for load factors

**Approximate weight: 9Kg**

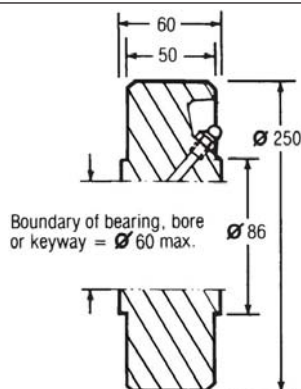

Axle Ø	Plain Bore	Plain Bore Keywayed	Ball Bearing	Taper Roller Bearing
<b>METRIC AXLE Ø</b>				
30	C250/50/PBM 30	C250/50/KM 30	C250/50/BJM 30	
35	C250/50/PBM 35	C250/50/KM 35		
40	C250/50/PBM 40	C250/50/KM 40		
50	C250/50/PBM 50	C250/50/KM 50		

# Cast Iron Untyred Wheels



## WHEEL TYPE: C250/75

See table for full part number

Maximum load rating:  
**2500Kg**

See page 23-26 for load factors

Approximate weight: **14Kg**

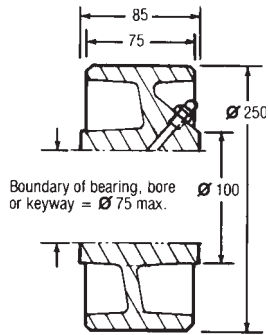

### FULL PART NUMBER FOR ORDERING

Axle Ø	Plain Bore	Plain Bore Keywayed	Ball Bearing	Taper Roller Bearing
--------	------------	---------------------	--------------	----------------------

METRIC AXLE Ø				
30	C250/75/PBM 30	C250/75/KM 30	C250/75/BJM 30	
35	C250/75/PBM 35	C250/75/KM 35	C250/75/BJM 35	
40	C250/75/PBM 40	C250/75/KM 40		
50	C250/75/PBM 50	C250/75/KM 50		

LOAD LIMITED BY BEARINGS TO: (1) 2040Kg

## WHEEL TYPE: C250/100

See table for full part number

Maximum load rating:  
**3300Kg**

See page 23-26 for load factors

Approximate weight: **17Kg**

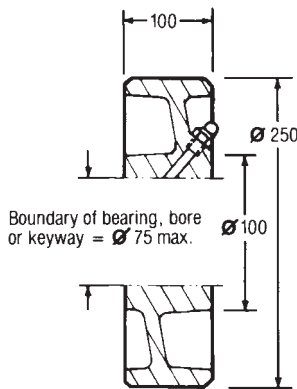

### METRIC AXLE Ø

35	C250/100/PBM 35	C250/100/KM 35	C250/100/BJM 35	
40	C250/100/PBM 40	C250/100/KM 40	C250/100/BJM 40	
50	C250/100/PBM 50	C250/100/KM 50		
60	C250/100/PBM 60	C250/100/KM 60		

LOAD LIMITED BY BEARINGS TO: (1) 2800Kg

## WHEEL TYPE: C350/100

See table for full part number

Maximum load rating:  
**4600Kg**

See page 23-26 for load factors

Approximate weight: **36Kg**

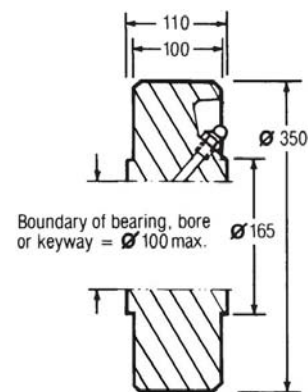

### METRIC AXLE Ø

35	C350/100/PBM 35	C350/100/KM 35	C350/100/BJM 35	
40	C350/100/PBM 40	C350/100/KM 40	C350/100/BJM 40	
50	C350/100/PBM 50	C350/100/KM 50	C350/100/BJM 50	
60	C350/100/PBM 60	C350/100/KM 60		

LOAD LIMITED BY BEARINGS TO: (1) 2800Kg (2) 3384Kg

## WHEEL TYPE: C350/125

See table for full part number

Maximum load rating:  
**5700Kg**

See page 23-26 for load factors

Approximate weight: **44Kg**

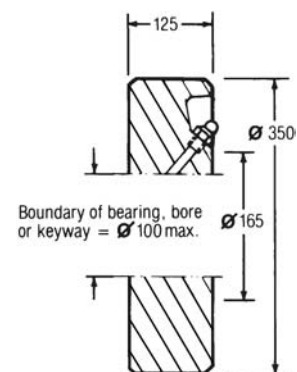

### METRIC AXLE Ø

40	C350/125/PBM 40	C350/125/KM 40	C350/125/BJM 40	
50	C350/125/PBM 50	C350/125/KM 50	C350/125/BJM 50	
60	C350/125/PBM 60	C350/125/KM 60		

LOAD LIMITED BY BEARINGS TO: (1) 3384Kg

CAST IRON UNTYRED





Brauer HEAVITHANE™ Polyurethane is resilient, durable material, resistant to abrasion and to many common chemicals. Polyurethane tyred wheels are capable of carrying heavy loads and of transmitting driving forces.

**MATERIAL:** Wheel centre – cast iron to BS1452: 1977: Grade 200 or steel to BS970: Part 1: 1983: 080M40.  
Tyre – Polyester based polymer of 92± 3° A Shore hardness.

**OPERATING TEMPERATURE RANGE:**  
-20°C to +60°C (115°C for limited use)

PLEASE SPECIFY IF OPERATING IN HIGH HUMIDITY.

**Anti-hydrolysis polyurethane is recommended for use in an operating environment of high humidity.**

**Polyurethane to the above hardness used on these wheels is Vulkollan, a high quality material that provides superior performance in most applications.**

**Should the mechanical properties of standard Vulkollan be inappropriate for the application, alternative grades of Polyurethane can be produced to meet the requirements. Polyurethane can be bonded onto most metal centres including aluminium, titanium, stainless steel and various ferrous and non-ferrous alloys.**

The 'maximum load rating' given for each wheel is for operation under ideal conditions. Load factors must be applied according to the anticipated working conditions – see 'Design Data' para. 5.1.

For wheels of larger diameter or greater load capacity see the PH series on pages 81-84. Alternative bore/bearing diameters and alternative bearing types (i.e. bronze bushes, self-lubricating bushes, roller bearings, spherical roller bearings, etc.) are available to order – see page 26-27.

For technical information covering load factors, chemical resistance, inertial and rolling resistance, coefficients of friction between wheel and surface, and keyway dimensions, see "Design Data" Index on page 20.

Drawings show grease nipple but standard wheels do not come with grease nipple unless specifically requested.

Tyres can be produced with crown/dome treads to suit specific applications.

ALLOWABLE LOADS @ 6KPH

**WHEEL TYPE:**

## H75/35

See table for full part number

**Maximum load rating:**  
**300Kg**

See page 22 for load factors

**Approximate weight: 0.5Kg**

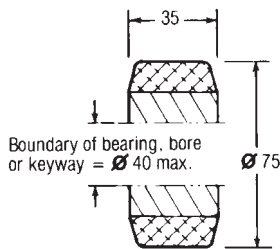

Wheels fitted with ball journals are pre-lubricated, double shielded

**WHEEL TYPE:**

## H85/75

See table for full part number

**Maximum load rating:**  
**700Kg**

See page 22 for load factors

**Approximate weight: 0.6Kg**

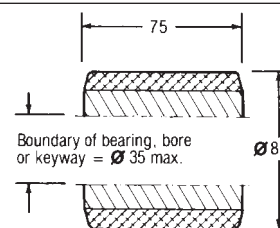

Wheels fitted with ball journals are pre-lubricated, double shielded

### FULL PART NUMBER FOR ORDERING

Axle Ø	Plain Bore	Plain Bore Keywayed	Ball Bearing	Taper Roller Bearing
<b>METRIC AXLE Ø</b>				
12	H75/35/PBM 12	H75/35/KM 12	H75/35/BJM 12	
20	H75/35/PBM 20	H75/35/KM 20	H75/35/BJM 20	
25	H75/35/PBM 25	H75/35/KM 25		
30	H75/35/PBM 30	H75/35/KM 30		

<b>METRIC AXLE Ø</b>				
20	N/A		H85/75/BJM 20	

# Polyurethane Tyred Wheels



Drawings show grease nipple but standard wheels do not come with grease nipple unless specifically requested.

**WHEEL TYPE:**  
**H100/40**  
See table for full part number

**Maximum load rating:**  
**450Kg**  
See page 22 for load factors

**Approximate weight: 1.5Kg**

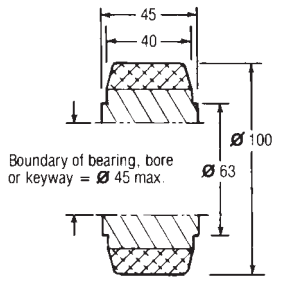

FULL PART NUMBER FOR ORDERING				
Axle $\varnothing$	Plain Bore	Plain Bore Keywayed	Ball Bearing	Taper Roller Bearing
<b>METRIC AXLE <math>\varnothing</math></b>				
12	H100/40/PBM 12	H100/40/KM 12	H100/40/BJM 12	
20	H100/40/PBM 20	H100/40/KM 20	H100/40/BJM 20	
25	H100/40/PBM 25	H100/40/KM 25	H100/40/BJM 25	
30	H100/40/PBM 30	H100/40/KM 30		
35	H100/40/PBM 35	H100/40/KM 35		

Wheels fitted with ball journals are pre-lubricated, double shielded

**WHEEL TYPE:**  
**H100/100**  
See table for full part number

**Maximum load rating:**  
**1100Kg**  
See page 22 for load factors

**Approximate weight: 5Kg**

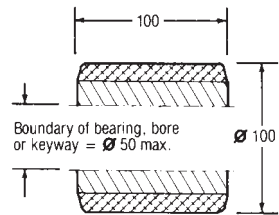

METRIC AXLE $\varnothing$				
20	N/A		H100/100/BJM 20	H100/100/TBM 20
25	N/A		H100/100/BJM 25	H100/100/TBM 25
30	N/A		H100/100/BJM 30	H100/100/TBM 30
35	N/A	H100/100/KM 35		

LOAD LIMITED BY BEARINGS TO: (1) 900Kg

Wheels fitted with ball journals are pre-lubricated, double shielded

**WHEEL TYPE:**  
**H125/30**  
See table for full part number

**Maximum load rating:**  
**400Kg**  
See page 22 for load factors

**Approximate weight: 1.5Kg**

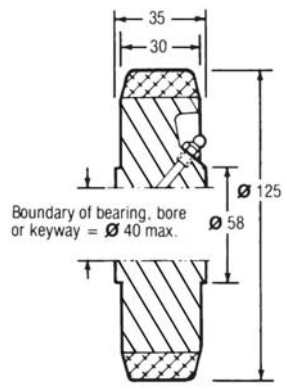

METRIC AXLE $\varnothing$				
20	H125/30/PBM 20	H125/30/KM 20	H125/30/BJM 20	
25	H125/30/PBM 25	H125/30/KM 25	H125/30/BJM 25	
30	H125/30/PBM 30	H125/30/KM 30		
35	H125/30/PBM 35	H125/30/KM 35		

**WHEEL TYPE:**  
**H125/45**  
See table for full part number

**Maximum load rating:**  
**600Kg**  
See page 22 for load factors

**Approximate weight: 2Kg**

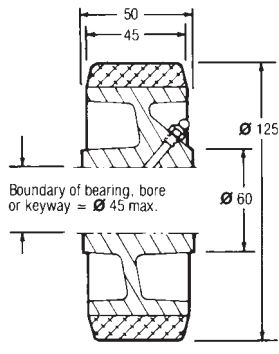

METRIC AXLE $\varnothing$				
25	H125/45/PBM 25	H125/45/KM 25	H125/45/BJM 25	
30	H125/45/PBM 30	H125/45/KM 30		
35	H125/45/PBM 35	H125/45/KM 35		

POLYURETHANE TYRED WHEELS

**WHEEL TYPE:**  
**H150/35**  
See table for full part number

**Maximum load rating:**  
**600Kg**  
See page 22 for load factors

**Approximate weight:** 2Kg

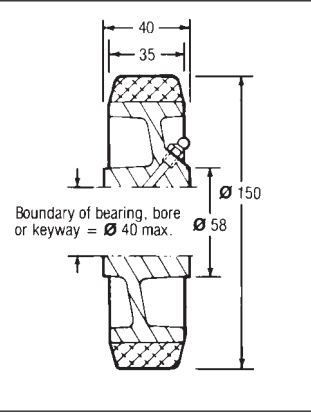

FULL PART NUMBER FOR ORDERING				
Axle Ø	Plain Bore	Plain Bore Keywayed	Ball Bearing	Taper Roller Bearing
<b>METRIC AXLE Ø</b>				
20	H150/35/PBM 20	H150/35/KM 20	H150/35/BJM 20	
25	H150/35/PBM 25	H150/35/KM 25	H150/35/BJM 25	
30	H150/35/PBM 30	H150/35/KM 30		

**WHEEL TYPE:**  
**H150/50**  
See table for full part number

**Maximum load rating:**  
**900Kg**  
See page 22 for load factors

**Approximate weight:** 3Kg

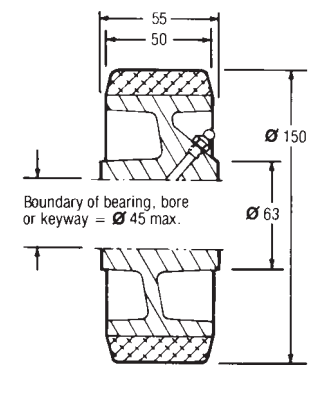

METRIC AXLE Ø				
25	H150/50/PBM 25	H150/50/KM 25	H150/50/BJM 25	H150/50/TBM 25
30	H150/50/PBM 30	H150/50/KM 30		
35	H150/50/PBM 35	H150/50/KM 35		

**WHEEL TYPE:**  
**H150/150**  
See table for full part number

**Maximum load rating:**  
**2300Kg**  
See page 22 for load factors

**Approximate weight:** 7Kg

Wheels fitted with ball journals are pre-lubricated, double shielded

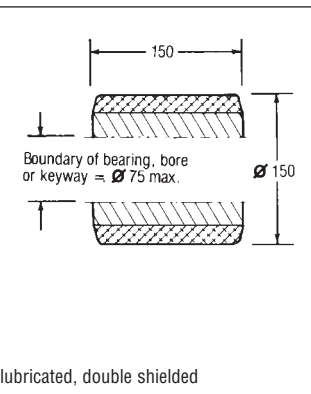

METRIC AXLE Ø				
25	N/A		H150/150/BJM 25 <sup>(1)</sup>	H150/150/TBM 25
30	N/A		H150/150/BJM 30 <sup>(2)</sup>	H150/150/TBM 30
35	N/A	H150/150/KM 35	H150/150/BJM 35	H150/150/TBM 35

LOAD LIMITED BY BEARINGS TO: (1) 1140kg (2) 2040Kg

**WHEEL TYPE:**  
**H200/40**  
See table for full part number

**Maximum load rating:**  
**900Kg**  
See page 22 for load factors

**Approximate weight:** 4Kg

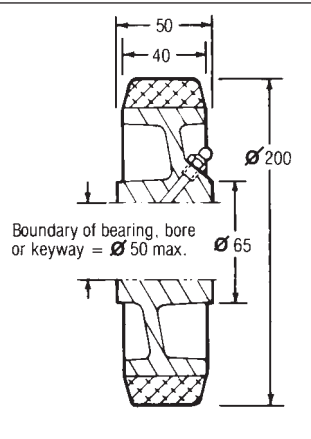

METRIC AXLE Ø				
25	H200/40/PBM 25	H200/40/KM 25	H200/40/BJM 25	H200/40/TBM 25
30	H200/40/PBM 30	H200/40/KM 30	H200/40/BJM 30	H200/40/TBM 30
35	H200/40/PBM 35	H200/40/KM 35		
40	H200/40/PBM 40	H200/40/KM 40		

# Polyurethane Tyred Wheels



**WHEEL TYPE:**  
**H200/60**  
See table for full part number

**Maximum load rating:**  
**1400Kg**  
See page 22 for load factors

**Approximate weight: 7Kg**

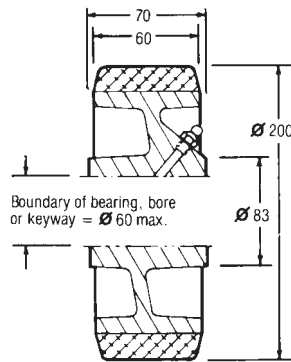

FULL PART NUMBER FOR ORDERING				
Axle Ø	Plain Bore	Plain Bore Keywayed	Ball Bearing	Taper Roller Bearing
<b>METRIC AXLE Ø</b>				
30	H200/60/PBM 30	H200/60/KM 30	H200/60/BJM 30	H200/60/TBM 30
35	H200/60/PBM 35	H200/60/KM 35		H200/60/TBM 35
40	H200/60/PBM 40	H200/60/KM 40		

**WHEEL TYPE:**  
**H200/75**  
See table for full part number

**Maximum load rating:**  
**1750Kg**  
See page 22 for load factors

**Approximate weight: 14.4Kg**

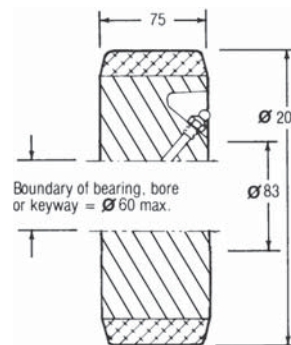

METRIC AXLE Ø				
25		H200/75/KM 25	H200/75/BJM 25	H200/75/TBM 25
30		H200/75/KM 30	H200/75/BJM 30	H200/75/TBM 30
35		H200/75/KM 35		
40		H200/75/KM 40		

LOAD LIMITED BY BEARINGS TO: (1) 1140Kg

**WHEEL TYPE:**  
**H250/45**  
See table for full part number

**Maximum load rating:**  
**1300Kg**  
See page 22 for load factors

**Approximate weight: 7Kg**

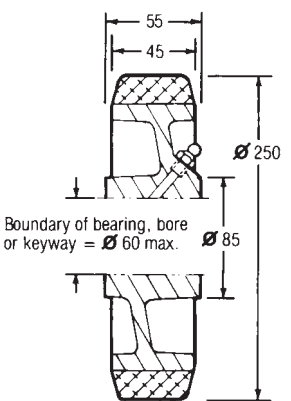

METRIC AXLE Ø				
30	H250/45/PBM 30	H250/45/KM 30	H250/45/BJM 30	H250/45/TBM 30
35	H250/45/PBM 35	H250/45/KM 35		H250/45/TBM 35
40	H250/45/PBM 40	H250/45/KM 40		

**WHEEL TYPE:**  
**H250/70**  
See table for full part number

**Maximum load rating:**  
**2000Kg**  
See page 22 for load factors

**Approximate weight: 12Kg**

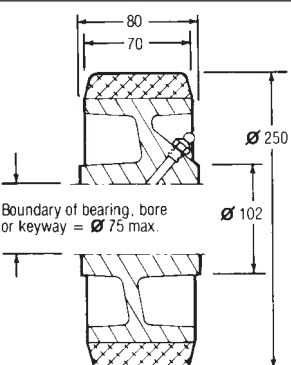

METRIC AXLE Ø				
30	H250/70/PBM 30	H250/70/KM 30	H250/70/BJM 30	H250/70/TBM 30
35	H250/70/PBM 35	H250/70/KM 35	H250/70/BJM 35	H250/70/TBM 35
40	H250/70/PBM 40	H250/70/KM 40		
50	H250/70/PBM 50	H250/70/KM 50		

POLYURETHANE TYRED WHEELS



**WHEEL TYPE:**  
**H250/97.5**

See table for full part number

**Maximum load rating:**  
**2700Kg**

See page 22 for load factors

**Approximate weight: 19.5Kg**

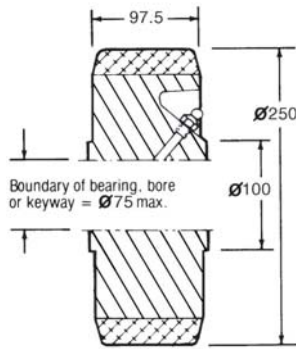

Wheels fitted with ball journals are pre-lubricated, double shielded

**FULL PART NUMBER FOR ORDERING**

Axle Ø	Plain Bore	Plain Bore Keywayed	Ball Bearing	Taper Roller Bearing
<b>METRIC AXLE Ø</b>				
40	H250/97.5/PBM 40	H250/97.5/KM 40	H250/97.5/BJM 40	H250/97.5/TBM 40
50	H250/97.5/PBM 50	H250/97.5/KM 50	H250/97.5/BJM 50	H250/97.5/TBM 50

**WHEEL TYPE:**  
**H300/50**

See table for full part number

**Maximum load rating:**  
**1500Kg**

See page 22 for load factors

**Approximate weight: 10Kg**

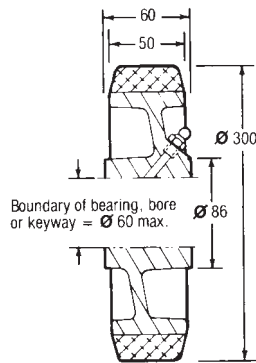

<b>METRIC AXLE Ø</b>				
30	H300/50/PBM 30	H300/50/KM 30	H300/50/BJM 30	H300/50/TBM 30
35	H300/50/PBM 35	H300/50/KM 35	H300/50/BJM 35	H300/50/TBM 35
40	H300/50/PBM 40	H300/50/KM 40		
50	H300/50/PBM 50	H300/50/KM 50		

**WHEEL TYPE:**  
**H300/75**

See table for full part number

**Maximum load rating:**  
**2300Kg**

See page 22 for load factors

**Approximate weight: 16Kg**

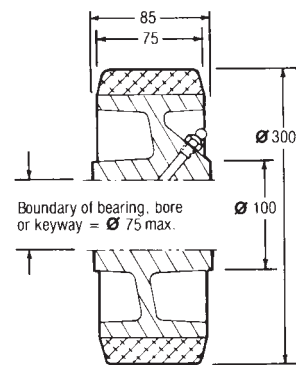

<b>METRIC AXLE Ø</b>				
35	H300/75/PBM 35	H300/75/KM 35	H300/75/BJM 35	H300/75/TBM 35
40	H300/75/PBM 40	H300/75/KM 40	H300/75/BJM 40	H300/75/TBM 40
50	H300/75/PBM 50	H300/75/KM 50		
60	H300/75/PBM 60	H300/75/KM 60		

**WHEEL TYPE:**  
**H300/100**

See table for full part number

**Maximum load rating:**  
**3100Kg**

See page 22 for load factors

**Approximate weight: 18Kg**

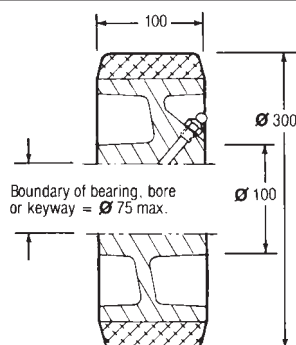

<b>METRIC AXLE Ø</b>				
40	H300/100/PBM 40	H300/100/KM 40	H300/100/BJM 40	H300/100/TBM 40
50	H300/100/PBM 50	H300/100/KM 50	H300/100/BJM 50	H300/100/TBM 50
60	H300/100/PBM 60	H300/100/KM 60		

# Polyurethane Tyred Wheels



## WHEEL TYPE: H350/100

See table for full part number

Maximum load rating:  
**3600Kg**

See page 22 for load factors

Approximate weight: **52Kg**

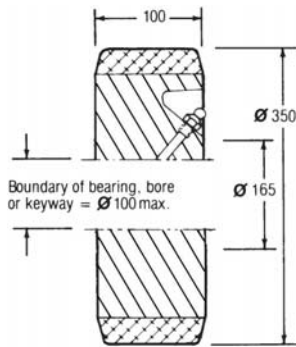

### FULL PART NUMBER FOR ORDERING

Axle Ø	Plain Bore	Plain Bore Keywayed	Ball Bearing	Taper Roller Bearing
<b>METRIC AXLE Ø</b>				
40		H350/100/KM 40	H350/100/BJM 40	H350/100/TBM 40
50		H350/100/KM 50	H350/100/BJM 50	H350/100/TBM 50
60		H350/100/KM 60	H350/100/BJM 60	H350/100/TBM 60

LOAD LIMITED BY BEARINGS TO: (1) 3384Kg

## WHEEL TYPE: H400/100

See table for full part number

Maximum load rating:  
**4200Kg**

See page 22 for load factors

Approximate weight: **39.5Kg**

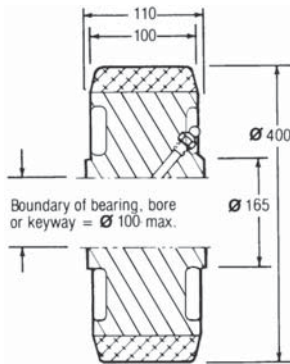

<b>METRIC AXLE Ø</b>				
50	H400/100/PBM 50	H400/100/KM 50	H400/100/BJM 50	H400/100/TBM 50
60	H400/100/PBM 60	H400/100/KM 60	H400/100/BJM 60	H400/100/TBM 60
75	H400/100/PBM 75	H400/100/KM 75	H400/100/BJM 75	H400/100/TBM 75

## WHEEL TYPE: H400/125

See table for full part number

Maximum load rating:  
**5200Kg**

See page 22 for load factors

Approximate weight: **48.5Kg**

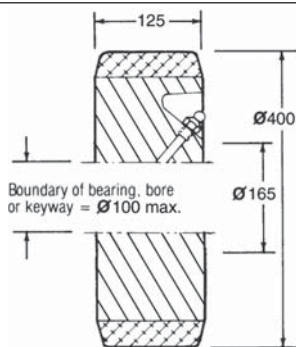

<b>METRIC AXLE Ø</b>				
50	H400/125/PBM 50	H400/125/KM 50	H400/125/BJM 50	H400/125/TBM 50
60	H400/125/PBM 60	H400/125/KM 60	H400/125/BJM 60	H400/125/TBM 60
75	H400/125/PBM 75	H400/125/KM 75	H400/125/BJM 75	H400/125/TBM 75

## WHEEL TYPE: H460/75

See table for full part number

Maximum load rating:  
**3500Kg**

See page 22 for load factors

Approximate weight: **40Kg**

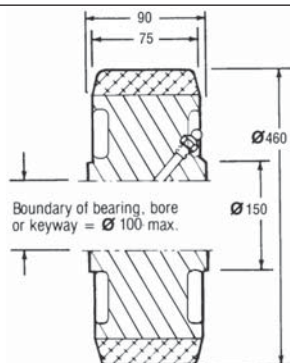

<b>METRIC AXLE Ø</b>				
50	H460/75/PBM 50	H460/75/KM 50	H460/75/BJM 50	
60	H460/75/PBM 60	H460/75/KM 60	H460/75/BJM 60	H460/75/TBM 60
75			H460/75/BJM 75	H460/75/TBM 75



MANUFACTURER	MODEL NUMBER	WHEEL SIZE
ATLET	75133	150 X 55
	78120	250 x 75
	72711	350 x 40
BT (Rola Truck)	134698	125 x 40
	171999	125 x 50
	156259	125 x 50
	46106	140 x 60
	171029	150 x 50
	129920	215 x 70
	135161	250 x 105
	137586	300 x 100
	143163	300 x 100
	151991	310 x 120
	162602	350 x 127

MANUFACTURER	MODEL NUMBER	WHEEL SIZE
JUNGHEINRICH	50019777	140 X 54
	27634500	150 x 54
	63210590	230 x 65
	63215600	230 x 78
	50052398	285 x 100
	50030509	343 x 114
STILL WAGNER	63145890	343 x 140
	426413	125 x 50
	412343	150 x 50
	359920	230 x 75
	365234	343 x 136
LANSING-LINDE	422980	400 x 160
	0009933803	125 x 60
	0029903807	285 x 100
	9815000599	330 x 135

# Vulkollan 90 Guide Rollers

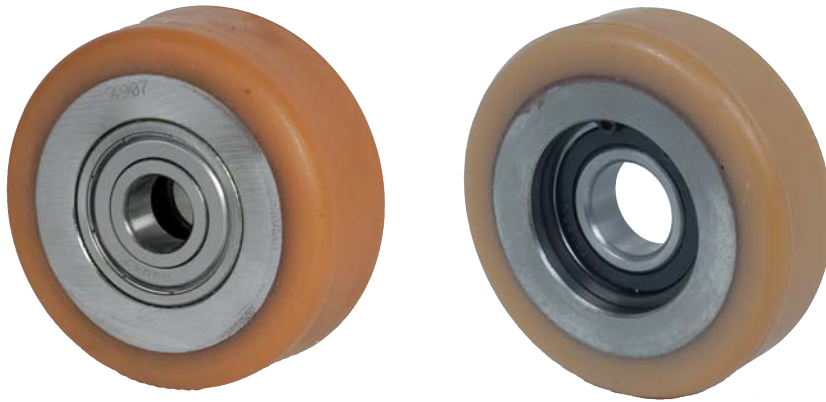

Temperature range of operation -40° to +85°C. The polyurethane is non-marking, with high resistance to axial loading, and runs quietly. Used in conveyor applications, systems of transporting products along material handling systems or in areas of support for hanging structures or components, as found in;

- escalators
- sorting
- overhead conveyors
- conveyors for letter & mail
- baggage handling airport equipment

Higher load capacity than Vulkopan, due to the chemical bonding and therefore far more resistant to axial forces. 92° shore hardness guarantees higher levels of elasticity and damping & improved traction. Finally, Vulkollan unlike Vulkopan can be machined after setting for specific tolerancing.

<b>NAME</b>		VULKOLLAN 90	
<b>ABBREVIATION</b>		VK90	
<b>COLOUR</b>		NATURAL	
<b>HARDNESS</b>	SHORE A/D	92/37	DIN 53505
<b>STRESS AT 100% STRAIN</b>	MPa	8.6	DIN 53504
<b>STRESS AT 300% STRAIN</b>	MPa	18.8	DIN 53504
<b>TENSILE STRENGTH</b>	MPa	42	DIN 53504
<b>ELONGATION AT BREAK</b>	%	650	DIN 53504
<b>TEAR PROPAGATION RESISTANCE</b>	kN/m	58	DIN 53515
<b>REBOUND</b>	%	55	DIN 53512
<b>ABRASION RESISTANCE</b>	mm <sup>3</sup>	42	DIN 53516
<b>DENSITY</b>	g/cm <sup>3</sup>	1.26	DIN 53479
<b>COMPRESSION SET %</b>	70 h / 23°C 70 h / 73.5°F	12	DIN 53517
	24 h / 70°C 24 h / 158°F	20	







VULKOLLAN 90 GUIDE ROLLERS

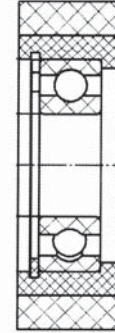
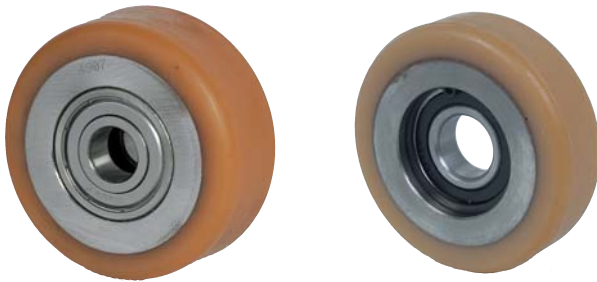







## 'VK' GUIDE ROLLER TECHNICAL INFORMATION

Polyurethane 92° Shore A: Hardness



						
VK RK 035 011 008 S	35	11	8	608-2RS	50	
VK RK 040 012 010 Z	40	12	10	6000-ZZ	60	
VK RK 040 015 010 S	40	15	10	6000-2RS	60	
VK RK 040 015 010 Z	40	15	10	6000-ZZ	60	
VK RK 040 016 012 Z	40	16	12	6001-ZZ	60	
VK RK 040 025 010 Z	40	25	10	6000-ZZ	60	
VK RK 045 015 015	45	15	15	61902-ZZ	70	
VK RK 045 038 010 S	45	38	10	6200-2RS	70	
VK RK 050 015 010 S	50	15	10	6000-2RS	85	
VK RK 050 015 012 SA	50	15	12	6001-2RS	85	
VK RK 050 015 012 Z	50	15	12	6001-ZZ	85	
VK RK 050 015 015 Z	50	15	15	6001-ZZ	85	
VK RK 050 018 012 Z	50	18	12	6201-ZZ	95	
VK RK 050 018 017 S	50	18	17	6003-2RS	95	
VK RK 050 018 020 Z	50	18	20	61804-ZZ	95	
VK RK 050 020 010 SB	50	20	10	6200-2RS	100	
VK RK 050 020 012 S	50	20	12	6201-2RS	100	
VK RK 050 020 012 ZB	50	20	12	6201-ZZ	100	
VK RK 050 020 017 Z	50	20	17	6003-ZZ	100	
VK RK 050 025 010 Z	50	25	10	6200-ZZ	105	
VK RK 050 025 012 S	50	25	12	6201-2RS	105	
VK RK 055 020 012 S	55	20	12	6201-2RS	105	
VK RK 055 020 015 S	55	20	15	6002-2RS	105	
VK RK 060 014 010 ZB	60	14	10	6200-ZZ	110	
VK RK 060 016 015 ZB	60	16	15	6202-ZZ	110	
VK RK 060 017 012 SB	60	17	12	6201-2RS	110	
VK RK 060 018 017 SA	60	18	17	6003-2RS	110	
VK RK 060 018 017 ZA	60	18	17	6003-ZZ	110	
VK RK 060 020 017 SA	60	20	17	6003-2RS	120	
VK RK 060 020 017 SB	60	20	17	6203-2RS	120	
VK RK 060 020 017 SK	60	20	17	6203-2RS	120	
VK RK 060 020 017 ZB	60	20	17	6203-ZZ	120	
VK RK 060 020 020 SA	60	20	20	6004-2RS	120	
VK RK 060 020 017 ZA	60	20	20	6004-ZZ	120	
VK RK 060 025 015 ZD	60	25	15	6002-ZZ	125	
VK RK 060 025 017 Z	60	25	17	6003-ZZ	125	
VK RK 060 025 020	60	25	20	6004-ZZ	125	

						
VK RK 065 016 020 S	65	16	20	6004-2RS	125	
VK RK 070 020 020 SB	70	20	20	6204-2RS	130	
VK RK 070 020 020 ZB	70	20	20	6204-ZZ	130	
VK RK 070 020 020 ZC	70	25	17	6303-ZZ	150	
VK RK 070 025 020 S	70	25	20	6204-2RS	150	
VK RK 070 025 020 Z	70	25	20	6204-ZZ	150	
VK RK 070 025 020 ZC	70	25	20	6304-ZZ	150	
VK RK 070 025 025 S	70	25	25	6205-2RS	150	
VK RK 070 025 025 Z	70	25	25	6005-ZZ	150	
VK RK 080 020 017 Z	80	20	17	6303-ZZ	150	
VK RK 080 020 020 Z	80	20	20	6304-ZZ	150	
VK RK 080 020 025 ZB	80	20	25	6205-ZZ	150	
VK RK 080 025 020 SA	80	25	20	6004-2RS	170	
VK RK 080 025 025 S	80	25	25	6205-2RS	170	
VK RK 080 025 025 Z	80	25	25	6205-ZZ	170	
VK RK 080 030 020 S	80	30	20	6204-2RS	180	
VK RK 080 030 020 Z	80	30	20	6204-ZZ	180	
VK RK 090 020 025 SB	90	20	25	6205-2RS	170	
VK RK 090 025 025 Z	90	25	25	6005-ZZ	190	
VK RK 090 035 020 Z	90	35	20	6304-ZZ	200	
VK RK 100 020 025 S	100	20	25	6205-2RS	190	
VK RK 100 020 025 ZB	100	20	25	6205-ZZ	190	
VK RK 100 025 020 Z	100	20	20	6204-ZZ	210	
VK RK 100 025 025 ZB	100	25	25	6205-ZZ	210	
VK RK 100 028 020 S	100	28	20	6204-2RS	215	
VK RK 100 030 020 ZC	100	30	20	6304-ZZ	220	
VK RK 100 030 025 S	100	30	25	6205-2RS	220	
VK RK 100 030 025 ZB	100	30	25	6205-ZZ	220	
VK RK 120 025 025 Z	120	25	25	6205-ZZ	250	
VK RK 120 030 030 S	120	30	30	6206-2RS	260	
VK RK 125 025 025 Z	125	25	25	6205-ZZ	260	
VK RK 125 030 025 S	125	30	25	6205-2RS	260	
VK RK 125 030 025 ZB	125	30	25	6205-ZZ	260	
VK RK 125 030 030 R	125	30	30	6206-2RS	260	
VK RK 125 030 030 Z	125	30	30	6306-ZZ	260	





Temperature range of operation  $-40^{\circ}$  to  $+85^{\circ}\text{C}$ . The polyurethane is non-marking, with high resistance to axial loading, and runs quietly. Used in conveyor applications, systems of transporting products along material handling systems or in areas of support for hanging structures or components, as found in;

- escalators
- overhead conveyors
- conveyors for letter & mail sorting
- baggage handling airport equipment





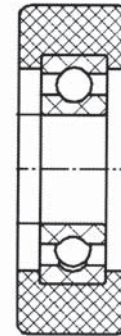

<b>NAME</b>		Vulkopan 59	
<b>ABBREVIATION</b>		WUPD	
<b>COLOUR</b>		LIGHT BROWN	
<b>HARDNESS</b>	SHORE D	59°	DIN 53505
<b>TENSILE STRENGTH</b>	MPa	50	DIN 53504
<b>ELONGATION AT BREAK</b>	%	500	DIN 53504
<b>ABRASION RESISTANCE</b>	mm <sup>3</sup>	20	DIN 53516
<b>COMPRESSION SET %</b>	70 h / 23°C 70 h / 73.5°F	30	DIN 53517
	24 h / 70°C 24 h / 158°F	50	







## 'WU' GUIDE ROLLER TECHNICAL INFORMATION

Polyurethane 59° Shore D: Hardness



VULKOPAN GUIDE ROLLERS

						
WU DP 018 006 004	18	6	4	684 ZZ	10	
WU DP 022 010 004	22	10	4	684 ZZ	20	
WU DP 025 010 006 S	25	10	6	626 2RS	20	
WU DP 025 010 006 Z	25	10	6	626 ZZ	20	
WU DP 026 012 006 Z	26	12	6	626 ZZ	25	
WU DP 030 011 008 S	30	11	8	608 2RS	30	
WU DP 030 011 008 Z	30	11	8	608 ZZ	30	
WU DP 030 011 009 S	30	11	9	609 2RS	20	
WU DP 030 011 009 Z	30	11	9	609 ZZ	20	
WU DP 032 016 008 S	32	16	8	608 2RS	45	
WU DP 032 016 008 Z	32	16	8	608 ZZ	45	
WU DP 035 009 006 S	35	9	6	626 2RS	40	
WU DP 035 011 008 S	35	11	8	608 2RS	40	
WU DP 035 011 008 Z	35	11	8	608 ZZ	40	
WU DP 035 015 010 Z	35	15	10	6000 ZZ	60	
WU DP 040 014 010 S	40	14	10	6200 2RS	70	
WU DP 040 014 010 Z	40	14	10	6200 ZZ	70	
WU DP 040 014 012 Z	40	14	12	6001 ZZ	70	
WU DP 040 020 010 S	40	20	10	6200 2RS	90	
WU DP 040 020 010 Z	40	20	10	6200 ZZ	90	
WU DP 040 025 010 Z	40	25	10	2X6000 ZZ	110	
WU DP 042 014 015 S	42	14	15	6002 2RS	80	
WU DP 044 012 012 Z	44	12	12	6001 ZZ	60	
WU DP 044 016 012 Z	44	16	12	6001 ZZ	80	
WU DP 045 013 012 Z	45	13	12	6001 ZZ	80	
WU DP 045 012 012 Z	45	15	12	6001 ZZ	80	
WU DP 047 013 012 Z	48	13	12	6001 ZZ	80	
WU DP 049 015 010 Z	49	15	10	6200 ZZ	80	
WU DP 050 012 015 Z	50	12	15	6002 ZZ	70	
WU DP 050 015 008 S	50	15	8	608 2RS	80	
WU DP 050 015 008 Z	50	15	8	608 ZZ	80	
WU DP 050 015 010 S	50	15	10	6200 2RS	100	
WU DP 050 015 010 Z	50	15	10	6200 ZZ	100	
WU DP 050 015 012 S	50	15	12	6201 2RS	100	
WU DP 050 015 012 Z	50	15	12	6201 ZZ	100	
WU DP 050 018 010 Z	50	18	10	6200 ZZ	100	
WU DP 050 018 012 S	50	18	12	6201 2RS	100	
WU DP 050 018 012 Z	50	18	12	6201 ZZ	100	
WU DP 050 018 015 S	50	18	15	6202 2RS	110	
WU DP 050 018 015 Z	50	18	15	6202 ZZ	110	
WU DP 050 018 017 S	50	18	17	6003 2RS	110	
WU DP 050 018 017 Z	50	18	17	6003 ZZ	110	
WU DP 050 025 012 S	50	25	12	6201 2RS	125	
WU DP 050 025 012 Z	50	25	12	6201 ZZ	125	
WU DP 050 025 015 Z	50	25	15	6202 ZZ	115	

						
WU DP 053 020 017 S	53	20	17	6203 2RS	75	
WU DP 055 020 012 Z	55	20	12	6201 ZZ	115	
WU DP 055 024 020 S	55	24	20	6204 2RS	80	
WU DP 055 024 020 Z	55	24	20	6204 ZZ	80	
WU DP 057 020 017 S	57	20	17	6203 2RS	135	
WU DP 057 020 017 Z	57	20	17	6203 ZZ	135	
WU DP 060 020 017 S	60	20	17	6203 2RS	150	
WU DP 060 020 017 Z	60	20	17	6203 ZZ	150	
WU DP 060 020 020 S	60	20	20	6004 2RS	150	
WU DP 060 020 020 Z	60	20	20	6004 ZZ	150	
WU DP 060 025 015 S	60	25	15	6202 SRS	150	
WU DP 060 025 015 Z	60	25	15	6202 ZZ	150	
WU DP 060 025 020 Z	60	25	20	6004 ZZ	150	
WU DP 062 020 017 Z	62	20	17	6203 ZZ	160	
WU DP 062 021 025 Z	62	21	25	6205 ZZ	180	
WU DP 063 020 017 Z	63	20	17	6203 ZZ	160	
WU DP 064 018 017 Z	64	18	17	6203 ZZ	150	
WU DP 064 020 017 Z	64	20	17	6203 ZZ	150	
WU DP 065 025 020 S	65	25	20	6204 2RS	150	
WU DP 065 025 020 Z	65	25	20	6204 ZZ	150	
WU DP 070 017 017 Z	70	17	17	6203 ZZ	100	
WU DP 070 025 020 S	70	25	20	6204 2RS	200	
WU DP 070 025 020 Z	70	25	20	6204 ZZ	200	
WU DP 070 035 020 Z	70	35	20	6204 ZZ	220	
WU DP 073 025 020 S	73	25	20	6204 2RS	210	
WU DP 073 025 020 Z	73	25	20	6204 ZZ	210	
WU DP 075 020 017 S	75	20	17	6303 2RS	160	
WU DP 075 020 017 Z	75	20	17	6303 ZZ	160	
WU DP 075 021 020 S	75	21	20	6204 2RS	160	
WU DP 075 021 020 Z	75	21	20	6204 ZZ	160	
WU DP 080 020 017 Z	80	20	17	6303 ZZ	175	
WU DP 080 025 025 S	80	25	25	6205 2RS	215	
WU DP 080 025 025 Z	80	25	25	6205 ZZ	215	
WU DP 085 025 020 Z	85	25	20	6304 ZZ	175	
WU DP 090 020 017 Z	90	20	17	6303 ZZ	195	
WU DP 090 020 025 Z	90	20	25	6205 ZZ	190	
WU DP 095 020 017 Z	95	20	17	6303 ZZ	170	
WU DP 100 025 025 Z	100	25	25	6205 ZZ	260	

# Vulkollan C Electrical Conductive Wheels



Brauer (conductive) is a new product in the Brauer range of wheels which are electrically conductive. This material corresponds to all the qualifications of the standards EN12527 to EN12533 and ISO 2878.

Regarding industrial wheels these standards indicate that an 'antistatic' wheel has a resistance between  $10^5$  and  $10^7$  Ohm. When the electrical resistance is smaller than or equal to  $10^4$  Ohm it may be called 'electrically conductive'.

Brauer Conductive wheels have a resistance which is considerably lower than  $10^4$  Ohm, so these wheels may be named electrically conductive.

They have the same advantages as the standard Vulkollan: very high load capacity, high resistance to wear and tear, resistant to oil and grease etc.

The only available colour of the tread is black and the hardness is around 92-95° shore A.

Vulkollan C is non-marking and the electrical characteristics do not change during the lifetime of the wheel.

As usual in the wheel industry for antistatic or electrically conductive wheels all Vulkollan Conductive wheel centres will be painted in black. The wheels are supplied with a yellow dot, which indicates that these wheels are electrically conductive.

Small series up to 15-20 pieces will be available in a short delivery time, bigger series are on request.

#### APPLICATION:

Environments with a higher danger of fire or explosion (eg gas/dust)

NAME		VULKOLLAN C	
ABBREVIATION		VKC	
COLOUR		Black	
HARDNESS	SHORE A/D	92/37	DIN 53505
STRESS AT 100% STRAIN	MPa	8.6	DIN 53504
STRESS AT 300% STRAIN	MPa	18.8	DIN 53504
TENSILE STRENGTH	MPa	42	DIN 53504
ELONGATION AT BREAK	%	650	DIN 53504
TEAR PROPAGATION RESISTANCE	kN/m	58	DIN 53515
REBOUND	%	55	DIN 53512
ABRASION RESISTANCE	mm <sup>3</sup>	42	DIN 53516
DENSITY	g/cm <sup>3</sup>	1.27	DIN 53479
COMPRESSION SET %	70 h / 23°C 70 h / 73.5°F	12	DIN 53517
	24 h / 70°C 24 h / 158°F	20	

VULKOLLAN C

### APPLICATION INFORMATION FOR VULKOLLAN<sup>®</sup> C

Companies that stock, produce or distribute explosive or inflammable materials are very apprehensive of the dangers involved. The consequences of an ignition can be disastrous and could lead to the destruction of production facilities or even worse, the loss of human life. These materials can be inflammable gas, fume, powder or dust. Mixed with oxygen they can cause an explosive atmosphere.

This explosive atmosphere can be subdivided into 3 different zones:

- Zone 0: where the explosive atmosphere is continually present or for longer periods of time
- Zone 1: where the explosive atmosphere is present continuously or for longer periods of time
- Zone 3: where under normal circumstances there is no danger or only for a very short period

When the dangerous substances exist of powder or dust the zones are respectively called zone 20, 21, 22.

#### Possible sources of ignition:

##### 1. For electrically driven vehicles:

- sparks deriving from unprotected electrical components
- hot surfaces such as braking discs
- sparks deriving from static electricity or friction

##### 2. For diesel driven vehicles:

- flames or sparks from exhaust valves or pipes
- flames or sparks from air inlets or vents
- excessive speed or overloading
- surface temperature of exhausts or other component such as brakes
- sparks deriving from unprotected electrical components
- sparks caused by discharge of static electricity or friction

#### European law has enacted some directives towards users and suppliers:

##### 1. Companies using or manufacturing inflammable materials:

This type of companies follow the Atex 1999/92/EC regulations also known as ATEX 137. These regulations premise the minimum requirements for safety and health protection for employees working in hazardous explosive environments.

One of the obligations the employer has, is to provide the necessary equipment that comes under the exact category for this respective zone.

- Zone 0 and 20: only equipment following Category 1
- Zone 1 and 21: only equipment following Category 1 and 2
- Zone 2 and 22: only equipment following Category 1, 2 and 3

##### 2. Companies supplying equipment in explosive environments:

This type of companies follow the Atex 94/9/EC regulations also known as ATEX 100a or 95.

- Category 1: very high level of security
- Category 2: high level of security
- Category 3: standard level of security

The category will be followed by a G (for gas, fume) or a D (for powder, dust) ex Cat 1 G: very high level of security for environments with gasification

Secured vehicles (category 1, 2 and 3) going faster than 6 km/h will be equipped with electrical conductive wheels.

For slower vehicles a wire in contact with the floor will be sufficient.

#### Fields of application:

Oil and gas, refineries, aerosol, powders, plastics, chemicals, paint industry, glue, explosives, varnish, lacquer, pharmaceuticals, aircraft fuel, coatings & ink, food, aromatic compounds, alcohol, cosmetics, distilleries.



# Polyurethane 'Press-on Band' Tyred Wheels

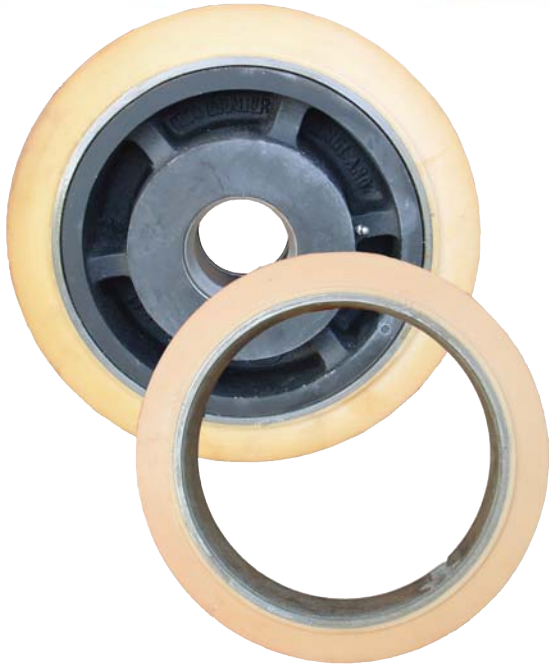

Unlike the less expensive polyurethane tyred wheels shown on pages 68-73 which have the tyre bonded directly to the wheel centre, 'Press-on Band' wheels have the tyre bonded to a thin steel band which is press-fitted to the wheel centre allowing the tyre to be replaced when worn.

**MATERIAL:** Wheel centre – cast iron to BS1452: 1977: Grade 200 or steel to BS970: Part 1: 1983: 080M40  
Tyre – Polyester based polymer of  $92 \pm 3^\circ\text{A}$  Shore hardness.

**OPERATING TEMPERATURE RANGE:**  
-20°C to +60°C (115°C for limited intermittent use).

PLEASE SPECIFY IF OPERATING IN HIGH HUMIDITY.

Anti-hydrolysis polyurethane is recommended for use in an operating environment of high humidity.

Polyurethane to the above hardness used on these wheels is Vulkollan, a high quality material that provides superior performance in most applications.

Should the mechanical properties of Vulkollan be inappropriate for the application, alternative grades of Polyurethane can be produced to meet the requirements. Polyurethane can be bonded onto most metal centres including aluminium, titanium, stainless steel and various ferrous and non-ferrous alloys.

For technical information covering load factors, chemical resistance, inertial and rolling resistance, coefficients of friction between wheel and track, and keyway dimensions, see "Design Data" Index on page 20.

Drawings show grease nipple but standard wheels do not come with grease nipple unless specifically requested.

Tyres can be produced with crown/dome treads to suit specific applications.

ALLOWABLE LOADS @ 6KPH

The 'maximum load rating' given for each wheel is for operation under ideal conditions. Load factors must be applied according to the anticipated working conditions – see 'Design Data' para. 5.1.

Alternative bore/bearing diameters and alternative bearing types (i.e. bronze bushes, self-lubricating bushes, roller bearings, spherical roller bearings, etc.) are available to order – see page 26-27.

**WHEEL TYPE:**  
**PH250/75**  
See table for full part number

Maximum load rating:  
**2000Kg**  
See page 22-23 for load factors  
Approximate weight: **20Kg**

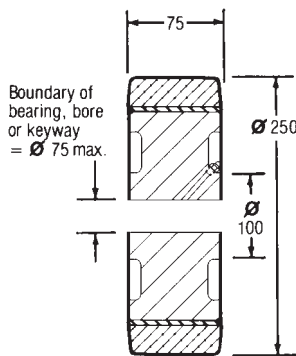

## FULL PART NUMBER FOR ORDERING

Axle Ø	Plain Bore	Plain Bore Keywayed	Ball Bearing	Taper Roller Bearing
<b>METRIC AXLE Ø</b>				
35		PH250/75/KM 35	PH250/75/BJM 35	PH250/75/TBM 35
40		PH250/75/KM 40	PH250/75/BJM 40	PH250/75/TBM 40
50		PH250/75/KM 50	PH250/75/BJM 50	PH250/75/TBM 50

<b>BAND ONLY PART NUMBER</b>
PH250/3

**WHEEL TYPE:**  
**PH250/125**  
See table for full part number

Maximum load rating:  
**3400Kg**  
See page 22-23 for load factors  
Approximate weight: **33Kg**

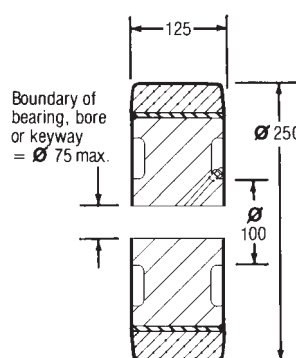

<b>METRIC AXLE Ø</b>				
35		PH250/125/KM 35	PH250/125/BJM 35	PH250/125/TBM 35
40		PH250/125/KM 40	PH250/125/BJM 40	PH250/125/TBM 40
50		PH250/125/KM 50	PH250/125/BJM 50	PH250/125/TBM 50

LOAD LIMITED BY BEARINGS TO: (1) 2800Kg (2) 3384Kg

<b>BAND ONLY PART NUMBER</b>
PH250/5

POLYURETHANE 'PRESS-ON-BAND'



**WHEEL TYPE:**  
**PH300/75**  
See table for full part number

**Maximum load rating:**  
**2550kg**  
See page 22-23 for load factors

**Approximate weight: 28kg**

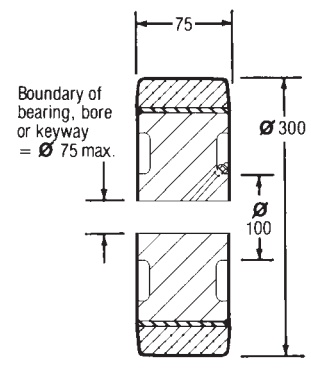

**FULL PART NUMBER FOR ORDERING**

Axle Ø	Plain Bore	Plain Bore Keywayed	Ball Bearing	Taper Roller Bearing
<b>METRIC AXLE Ø</b>				
40		PH300/75/KM 40	PH300/75/BJM 40	PH300/75/TBM 40
50		PH300/75/KM 50	PH300/75/BJM 50	PH300/75/TBM 50
60		PH300/75/KM 60	PH300/75/BJM 60	PH300/75/TBM 60

<b>BAND ONLY PART NUMBER</b>
PH300/3

**WHEEL TYPE:**  
**PH350/100**  
See table for full part number

**Maximum load rating:**  
**3600Kg**  
See page 22-23 for load factors

**Approximate weight: 40Kg**

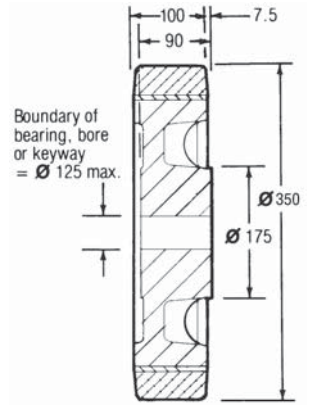

<b>METRIC AXLE Ø</b>				
50		PH350/100/KM 50	PH350/100/BJM 50	PH350/100/TBM 50
60		PH350/100/KM 60	PH350/100/BJM 60	PH350/100/TBM 60

<b>BAND ONLY PART NUMBER</b>
PH300/4

**WHEEL TYPE:**  
**PH380/75**  
See table for full part number

**Maximum load rating:**  
**2700Kg**  
See page 22-23 for load factors

**Approximate weight: 36Kg**

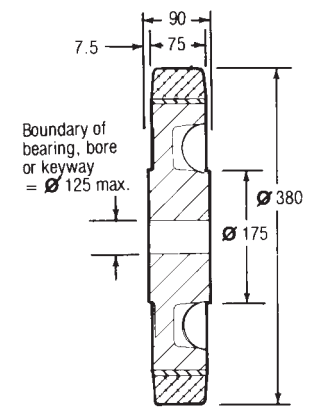

<b>METRIC AXLE Ø</b>				
50		PH380/75/KM 50	PH380/75/BJM 50	PH380/75/TBM 50
60		PH380/75/KM 60	PH380/75/BJM 60	PH380/75/TBM 60
75		PH380/75/KM 75	PH380/75/BJM 75	PH380/75/TBM 75

<b>BAND ONLY PART NUMBER</b>
PH380/3

**WHEEL TYPE:**  
**PH380/100**  
See table for full part number

**Maximum load rating:**  
**3600Kg**  
See page 22-23 for load factors

**Approximate weight: 45Kg**

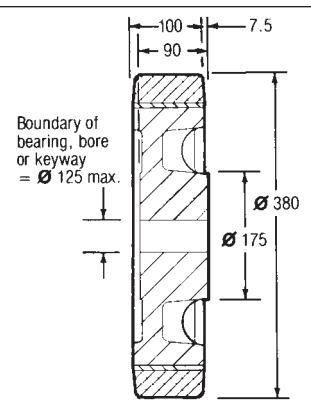

<b>METRIC AXLE Ø</b>				
60		PH380/100/KM 60	PH380/100/BJM 60	PH380/100/TBM 60
75		PH380/100/KM 75	PH380/100/BJM 75	PH380/100/TBM 75

<b>BAND ONLY PART NUMBER</b>
PH380/4

# Polyurethane 'Press-on Band' Tyred Wheels



**WHEEL TYPE:**  
**PH380/125**  
See table for full part number

**Maximum load rating:**  
**4500Kg**  
See page 22-23 for load factors  
**Approximate weight: 53Kg**

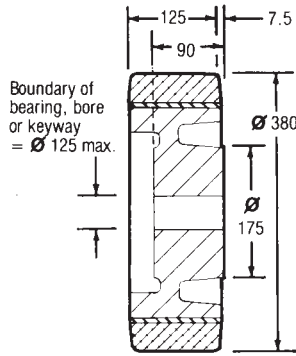

## FULL PART NUMBER FOR ORDERING

Axle Ø	Plain Bore	Plain Bore Keywayed	Ball Bearing	Taper Roller Bearing
<b>METRIC AXLE Ø</b>				
60		PH380/125/KM 60	PH380/125/BJM 60	PH380/125/TBM 60
75		PH380/125/KM 75	PH380/125/BJM 75	PH380/125/TBM 75

<b>BAND ONLY PART NUMBER</b>
PH380/5

**WHEEL TYPE:**  
**PH400/100**  
See table for full part number

**Maximum load rating:**  
**3800Kg**  
See page 22-23 for load factors  
**Approximate weight: 65Kg**

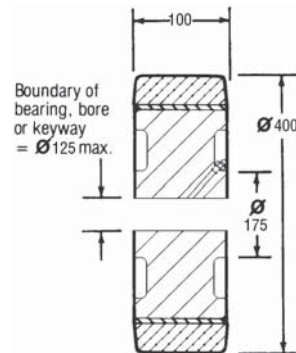

<b>METRIC AXLE Ø</b>				
60		PH400/100/KM 60	PH400/100/BJM 60	PH400/100/TBM 60
75		PH400/100/KM 75	PH400/100/BJM 75	PH400/100/TBM 75

<b>BAND ONLY PART NUMBER</b>
PH400/4

**WHEEL TYPE:**  
**PH400/125**  
See table for full part number

**Maximum load rating:**  
**4800Kg**  
See page 22-23 for load factors  
**Approximate weight: 80Kg**

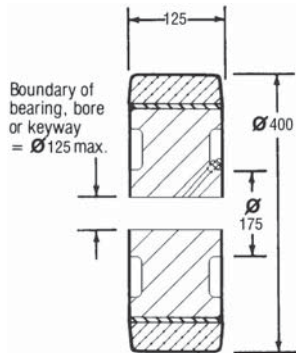

<b>METRIC AXLE Ø</b>				
60		PH400/125/KM 60	PH400/125/BJM 60	PH400/125/TBM 60
75		PH400/125/KM 75	PH400/125/BJM 75	PH400/125/TBM 75

<b>BAND ONLY PART NUMBER</b>
PH400/5

**WHEEL TYPE:**  
**PH460/75**  
See table for full part number

**Maximum load rating:**  
**3200Kg**  
See page 22-23 for load factors  
**Approximate weight: 45Kg**

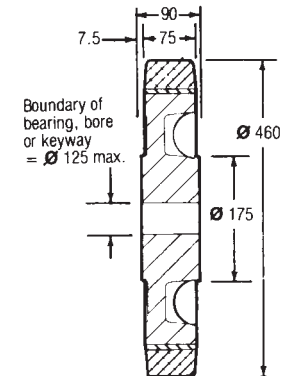

<b>METRIC AXLE Ø</b>				
60		PH460/75/KM 60	PH460/75/BJM 60	PH460/75/TBM 60
75		PH460/75/KM 75	PH460/75/BJM 75	PH460/75/TBM 75

<b>BAND ONLY PART NUMBER</b>
PH460/3

POLYURETHANE 'PRESS-ON-BAND'

**WHEEL TYPE:**  
**PH460/100**  
See table for full part number

**Maximum load rating:**  
**4200Kg**  
See page 22-23 for load factors  
**Approximate weight: 52Kg**

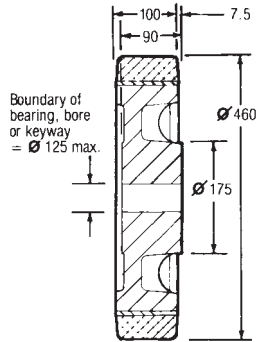

**FULL PART NUMBER FOR ORDERING**

Axle Ø	Plain Bore	Plain Bore Keywayed	Ball Bearing	Taper Roller Bearing
<b>METRIC AXLE Ø</b>				
60		PH460/100/KM 60	PH460/100/BJM 60	PH460/100/TBM 60
75		PH460/100/KM 75	PH460/100/BJM 75	PH460/100/TBM 75

<b>BAND ONLY PART NUMBER</b>
PH460/4

**WHEEL TYPE:**  
**PH500/75**  
See table for full part number

**Maximum load rating:**  
**3600Kg**  
See page 22-23 for load factors  
**Approximate weight: 65Kg**

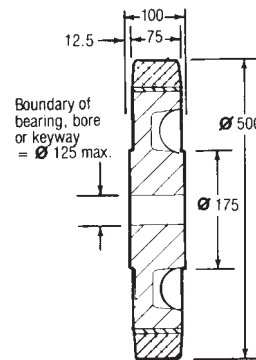

<b>METRIC AXLE Ø</b>				
75		PH500/75/KM 75	PH500/75/BJM 75	PH500/75/TBM 75
100		PH500/75/KM 100	PH500/75/BJM 100	PH500/75/TBM 100

<b>BAND ONLY PART NUMBER</b>
PH500/3

**WHEEL TYPE:**  
**PH500/100**  
See table for full part number

**Maximum load rating:**  
**4800Kg**  
See page 22-23 for load factors  
**Approximate weight: 70Kg**

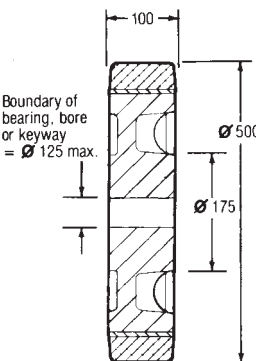

<b>METRIC AXLE Ø</b>				
75		PH500/100/KM 75	PH500/100/BJM 75	PH500/100/TBM 75
100		PH500/100/KM 100	PH500/100/BJM 100	PH500/100/TBM 100

<b>BAND ONLY PART NUMBER</b>
PH500/4

# Rubber Tyred Wheels



Rubber tyred wheels are the least expensive type of tyred wheel and are suitable for moderate loads. They are quiet in operation and protect the surface on which they run, although they can cause marking. Rubber tyres can generate static electricity, and where this is undesirable, 'anti-static' tyres can be specified.

**MATERIAL:** Wheel centre-cast iron to BS1452: 1977: Grade 200.  
Tyre-carbon black reinforced natural rubber compound of  $85^{\circ}\pm 5^{\circ}$ A Shore hardness.

**OPERATING TEMPERATURE RANGE:**  
 $0^{\circ}\text{C}$  to  $50^{\circ}\text{C}$ .

The 'maximum load rating' given for each wheel is for operation under ideal conditions. Load factors must be applied according to the anticipated working conditions – see 'Design Data' para. 3.1.

Alternative bore/bearing diameters and alternative bearing types (i.e. bronze bushes, self-lubricating bushes, roller bearings, spherical roller bearings, etc.) are available to order – see page 26-27.

For technical information covering load factors, inertial and rolling resistance, coefficients of friction between wheel and surface, and keyway dimensions, see "Design Data" Index on page 20.

Drawings show grease nipple but standard wheels do not come with grease nipple unless specifically requested.

**WHEEL TYPE:**  
**R100/40**  
See table for full part number

**Maximum load rating:**  
**120Kg**  
See page 21 for load factors  
**Approximate weight: 1.5Kg**

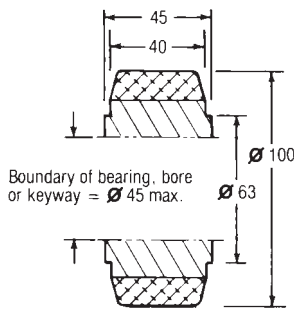

FULL PART NUMBER FOR ORDERING				
Axle $\varnothing$	Plain Bore	Plain Bore Keywayed	Ball Bearing	Taper Roller Bearing
<b>METRIC AXLE <math>\varnothing</math></b>				
12	R100/40/PBM 12	R100/40/KM 12	R100/40/BJM 12	
20	R100/40/PBM 20	R100/40/KM 20	R100/40/BJM 20	
25	R100/40/PBM 25	R100/40/KM 25		

Wheels fitted with ball journals are pre-lubricated, double shielded

**WHEEL TYPE:**  
**R125/30**  
See table for full part number

**Maximum load rating:**  
**150Kg**  
See page 21 for load factors  
**Approximate weight: 1.5Kg**

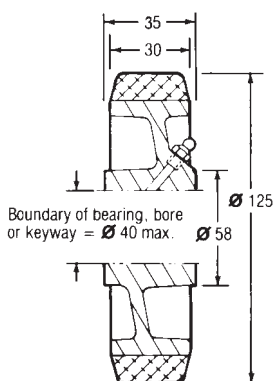

METRIC AXLE $\varnothing$				
20	R125/30/PBM 20	R125/30/KM 20	R125/30/BJM 20	
25	R125/30/PBM 25	R125/30/KM 25		
30	R125/30/PBM 30	R125/30/KM 30		

RUBBER TYRED WHEELS

**WHEEL TYPE:**

## R150/50

See table for full part number

**Maximum load rating:**

**400Kg**

See page 21 for load factors

**Approximate weight: 3Kg**

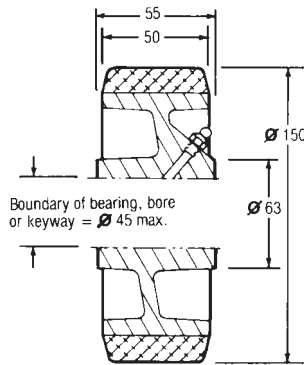

### FULL PART NUMBER FOR ORDERING

Axle Ø	Plain Bore	Plain Bore Keywayed	Ball Bearing	Taper Roller Bearing
<b>METRIC AXLE Ø</b>				
20			R150/50/BJM 20	
25	R150/50/PBM 25	R150/50/KM 25	R150/50/BJM 25	
30	R150/50/PBM 30	R150/50/KM 30		

**WHEEL TYPE:**

## R200/40

See table for full part number

**Maximum load rating:**

**400Kg**

See page 21 for load factors

**Approximate weight: 4Kg**

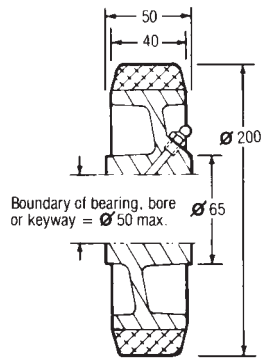

<b>METRIC AXLE Ø</b>				
20			R200/40/BJM 20	
25	R200/40/PBM 25	R200/40/KM 25	R200/40/BJM 25	
30	R200/40/PBM 30	R200/40/KM 30		





Plain untyred nylon wheels are the least expensive type of wheel. They are light in weight, and are resistant to impact, abrasion, corrosion, and the effect of many chemicals. They can be fitted with bearings but are most often used with their nylon bores running on a smooth steel axle. No lubrication is necessary, but they will benefit from being oiled. Having little resilience they tend to be noisiest when moving quickly over rough surfaces, and they can mark floors if highly loaded.

**OPERATING TEMPERATURE RANGE:** 5°C to 40°C  
(-20°C to 80°C for limited use).

Nylon wheels are resistant to oils fats, alkalis in general, soaps and detergents but should not be used in contact with acids.

UNTYRED NYLON

<b>PART NUMBER:</b> <b>N50/14/PBM12</b> <b>PLAIN BORE</b>	
<b>Maximum load rating:</b> <b>80Kg</b> See page 21 for load factors <b>Approximate weight: 0.03Kg</b>	
<b>PART NUMBER:</b> <b>N63/23/PBM11</b> <b>PLAIN BORE</b>	
<b>Maximum load rating:</b> <b>85Kg</b> See page 21 for load factors <b>Approximate weight: 0.05Kg</b>	
<b>PART NUMBER:</b> <b>N75/25/PBM12</b> <b>PLAIN BORE</b>	
<b>Maximum load rating:</b> <b>120Kg</b> See page 21 for load factors <b>Approximate weight: 0.07Kg</b>	

<b>PART NUMBER:</b> <b>N100/32/PBM15</b> <b>PLAIN BORE</b>	
<b>Maximum load rating:</b> <b>225Kg</b> See page 21 for load factors <b>Approximate weight: 0.15Kg</b>	
<b>PART NUMBER:</b> <b>N150/40/RBM20</b> <b>ROLLER BEARING</b>	
<b>Maximum load rating:</b> <b>500Kg</b> See page 21 for load factors <b>Approximate weight: 0.5Kg</b>	<small>ENVELOPE DRAWING ONLY</small>
<b>PART NUMBER:</b> <b>N250/60/BJM25</b> <b>BALL JOURNAL</b>	
<b>Maximum load rating:</b> <b>2000Kg</b> See page 21 for load factors <b>Approximate weight: 2.3Kg</b>	<small>ENVELOPE DRAWING ONLY</small>

Fitted with pre-lubricated, double shielded bearings.