

### 480045 TAPÓN CABEZA HEXAGONAL TTE

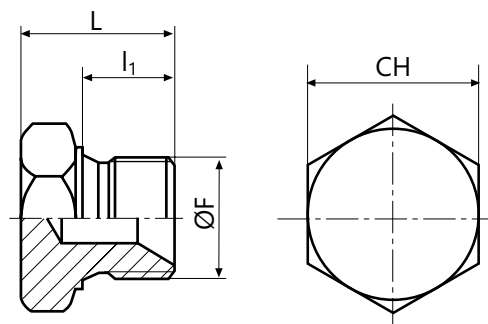

Material: Acero 115MnPb37.  
Temperatura de trabajo: -20 ° C + 100 ° C.

Código	F	l1	L	CH
48004500300	G 1/8"	8	13	14
48004500600	G 1/4"	11	17	19
48004500900	G 3/8"	12	19	22
48004501200	G 1/2"	14	22	27
48004501900	G 3/4"	16	25	32
48004502500	G 1"	19	29	41
48004503100	G 1 1/4"	20	31	50
48004503700	G 1 1/2"	21	33	55
48004511000	M 10x1	8	12	14
48004511200	M 12x1.5	10	15	17
48004511400	M 14x1.5	11	17	19
48004511600	M 16x1.5	12	19	22
48004511800	M 18x1.5	13	20	24
48004512000	M 20x1.5	14	22	27
48004512200	M 22x1.5	15	23	27
48004512400	M 24x1.5	16	25	30
48004512600	M 26x1.5	16	25	32